

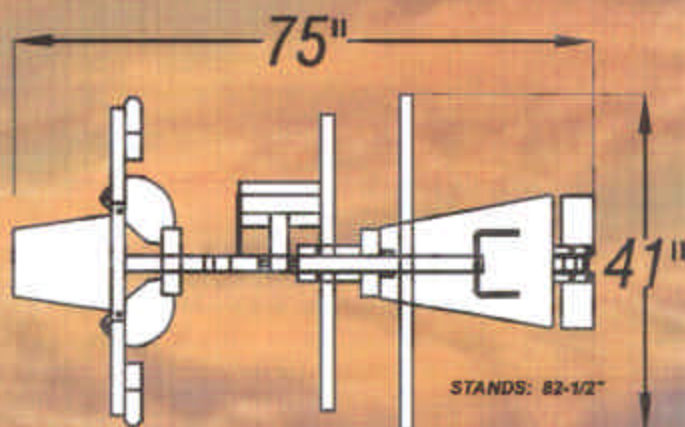

MAXIMUSTM
FITNESS PRODUCTS



MX800

DESIGNED TO MEET YOUR FITNESS' NEEDS
STRENGTH SYSTEMS SHAPING YOUR FUTURE

MX800
PREMIER HOME GYM SYSTEM



SHROUDS ARE OPTIONAL

MULTI-STATION GYMS, SELECTORIZED MACHINES,
FREE WEIGHTS, AND BENCHES

Since 1979

208 East 2nd Avenue, LaHabra CA. 90631 Tel: (562) 694-0800 (800) 634-6294 Fax: (562) 694-6283
E-mail: FITMAX@pacbell.net

SPECIFICATIONS:

- Biomechanically Engineered.*
- Components: Commercial grade*
- Frame: Rugged Steel Construction.*
- Finish: Durable electrostatic powder coating.*
- Cable: Aircraft quality nylon coated cable tested for 2200 lbs.*
- Pulleys: Sealed ball bearings tested at 1 million cycles with 400 lbs. of weights, fiberglass reinforced channel to ensure cable support.*
- Pivot points: Sealed ball bearings and oil impregnated sintered iron bushings for added smoothness and quiet movement.*
- Guide Rods: 1: Chrome plated guide rods along with weight plate bushings provide smooth action.*
- Weight Stack: Cast iron plates, 1" thick are fitted with long lasting nylon bushing eliminating metal to metal friction.*
- Top Plate: Steel with nylon bushings*
- Adjustments/ Seat post: Chromed finish with spring loaded pop-pin mechanism.*
- Upholstery: Heavy duty thick foam padding covered with commercial grade vinyl; customized with double stitched seams on high density foam.*
- 3-D dimensional Computerized Assembly Instructions for easier understanding.*
- Packaging: All components are securely strapped in individual compartments.*
- Limited Lifetime Warranty.*

MX800

FEATURES:

- 200lb. Weight stack*
- Abdominal crunch*
- Lat Hold down pads*
- Seated leg developer with adjustable seat*
- Slip covers on all foam rollers*
- Articulating handles or pads on pec dec*
- Adjustable Pec Dec Seat*
- Range of motion on press station*
- Adjustable back Press-Dad: (3 settings)*
- Leg Press or Multi-Hip Option*
- Two low pulleys (one may be utilized for above options.)*
- Standard Accessories: Lat Bar, Ankle Strap, D-handle, AB-strap, and Curl bar*
- Anatomical Exercise Wall Chart*

MODELS:

MX800 Standard:

- No range of motion on pec dec station*
- Standard Upholstery*

MX800 Deluxe:

- Standard Pec Dec Station*
- Custom Double Stitched Upholstery*
- Calf Block/Row attachment*
- Handles on leg extension seat*

MX800 Premier:

- Same as 800 Deluxe*
- Weight Stack Enclosures (Shrouds)*

OPTIONS:

- * *Weight Stack Enclosures (Shrouds)*
- * *Multi-Hip or Leg Press*

EXERCISES:

- * *BENCH PRESS*
- * *SHOULDER PRESS*
- * *CALF RAISE*
- * *PECTORALS*
- * *SEATED LEG EXTENSIONS*
- * *STANDING LEG CURL*
- * *SEATED ROWS*
- * *BENT OVER ROWS*

- * *LOW ROWS*
- * *LAT PULLDOWNS*
- * *TRICEPS PUSHDOWNS*
- * *TRICEPS EXTENSIONS*
- * *CLOSE GRIP PUSHDOWNS*
- * *BICEPS CURLS*
- * *REVERSE CURLS*
- * *SINGLE ARM CURLS*

- * *INNER THIGH*
- * *OUTER THIGH*
- * *SIDE LATERALS*
- * *BENT OVER LATERALS*
- * *SITUPS*

LIMITED LIFETIME WARRANTY:

Under normal use, conditions and with proper maintenance. Limited lifetime on frame and welds. Five years pulleys and bearings. Ninety days on cables and upholstery. Call manufacturer / distributor for details on commercial warranties where applicable.